

# FOXPRO<sup>®</sup>

*High Performance Game Calls*



# **PATRIOT<sup>™</sup>**

## **INSTRUCTION MANUAL**



FOXPRO Inc. • 14 Fox Hollow Drive • Lewistown, PA 17044 • (717)-248-2507

**WWW.GOFOXPRO.COM**

## **Important Information**

FOXPRO®'s goal is to provide our customers with the highest quality products in the industry. We take great pride in manufacturing our products in the USA. Please do not hesitate to contact us for assistance, comments or questions.

### **FOXPRO® Inc.**

14 Fox Hollow Drive  
Lewistown, PA 17044

## **Hours of Operation**

Monday – Friday  
8AM – 5PM EST

## **Contact Us**

**Service & Support:** 717-248-2507

**Toll Free Orders Only:** 866-463-6977

**General Inquiry E-mail:** sales@gofoxpro.com

**Technical Support:** techsupport@gofoxpro.com

Stay up to date with the latest sounds, products, and videos on  
Facebook:

**<https://www.facebook.com/Foxpro.Furtakers>**

This manual, the animal sounds stored in your caller, and animal sounds purchased from FOXPRO® Inc. for installation in your caller are protected by copyright.

Copyright ©© 2022 by FOXPRO® Inc.  
Publication Date: September 25, 2023 – REV2

# 1. Getting Started

**Congratulations** on your purchase of the FOXPRO Patriot digital game call! To avoid personal injury and product damage, be sure to read all operating instructions before using the FOXPRO Patriot.

## 1-1 Patriot Overview

The following graphic highlights the functions and details of the Patriot digital game call:



1. Rugged injection molded ABS housing.
2. The horn speaker is located on the right side of the Patriot.
3. The power on/off slide switch is located on the leftmost side of the control panel.
4. The speaker on/off slide switch is located to the right of the power switch.

5. The auxiliary device jack is located under the power switch.
6. The external speaker jack is located to the right of the auxiliary device jack.
7. The pilot lamp/low battery indicator is located under the speaker switch.
8. The tripod mount is found on the underside of the Patriot.
9. The USB port access door is located on the rear of the Patriot.
10. The battery compartment is located on the side opposite the control panel.

## 1-2 TX433 Transmitter Overview

The following graphic highlights the functions and details of the Patriot TX433 transmitter:

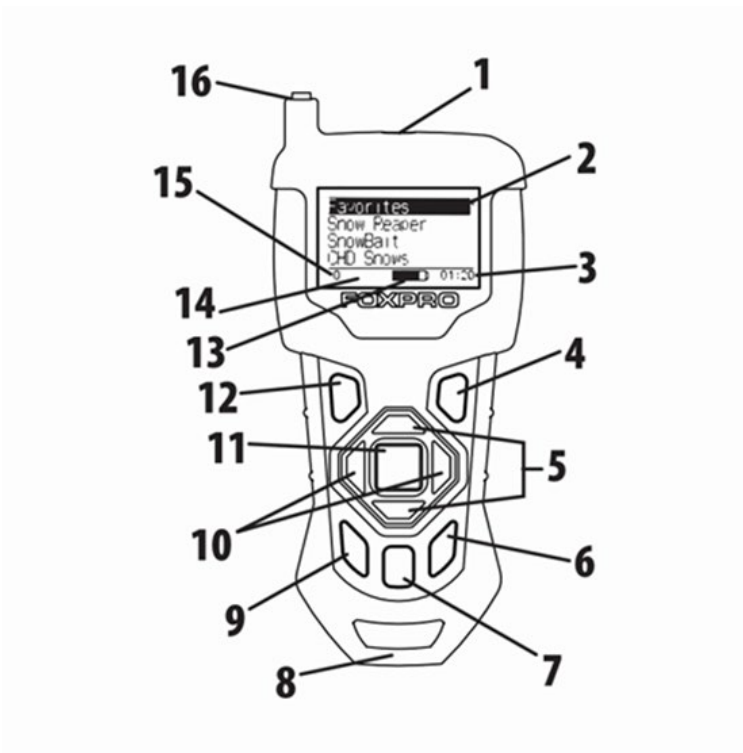

1. The sound list upload jack is located on the top center of the TX433.
2. The screen consumes the largest upper portion of the TX433.
3. In the lower-right corner of the screen is the elapsed stand timer.
4. On the lower keypad portion of the TX433, the Back/Menu button is to the upper right.
5. In the center of the TX433 is a large button. Directly above and below this button are the Scroll Up and Scroll down buttons.
6. The User 2 button is located on the bottom right.
7. The Mute button is located to the left of the User 2 button.
8. The lanyard loop is located on the bottom of the TX433.
9. The User 1 button is located to the left of the Mute button.
10. The Volume Up and Volume Down buttons are located to the left and right of the large button in the middle.
11. The Play/Select button is the largest button in the middle of the TX433.
12. The Power button is located on the upper left of the keypad.
13. The Battery Level Indicator is located to the left of the elapsed timer on the screen.
14. The Mute Status Indicator is located to the left of the Battery Level Indicator.
15. The Volume Level Indicator is located to the left of the Mute Status Indicator.
16. The antenna is located on the top left of the TX433.

## **2. Operating Manual**

The Operating Manual explains how to use the Patriot Digital Game Call. We strongly suggest reading the manual in its entirety to fully understand all of the features and get the most of your new product.

## **2-1 Patriot Requirements**

The Patriot ships from the factory without batteries. The Patriot requires 4 'AA' batteries (not included). We recommend the use of lithium, rechargeable NiMH, or high-quality alkaline batteries for the best performance. If you plan on operating the Patriot in cold conditions (under 32°F/0°C), we suggest lithium batteries for maximum run times. Alkaline batteries do not last nearly as long in colder temperatures.

### **Installing Batteries in the Patriot**

1. Open the battery compartment on the side of the Patriot. You might need to use a coin or a flathead screwdriver to release the tab.
2. Locate and remove the plastic battery holder from the battery compartment. The battery holder attaches to a red and black power wire.
3. Place the 'AA' batteries into each battery cavity of the battery holder while observing correct polarity as indicated on the battery tray.
4. If you disconnected the power wire from the battery holder, reconnect it.
5. Place the battery holder back into the battery compartment and replace the battery compartment door (see image below).



6. To verify that you have power: Slide the power switch to the “on” position (to the right). The pilot LED should illuminate green, indicating that the Patriot is powered on. If the LED does not illuminate, verify that your batteries are fresh and double-check the connections. The LED may flicker for a period of time before glowing solid when the Patriot is initially powered on. This is normal. If the LED begins blinking during operation, it indicates the batteries are low and need replaced or recharged.

## **2-2 TX433 Requirements**

The TX433 remote control operates on a single 9V battery (not included). It is recommended that you use a high-quality lithium or alkaline battery for the best performance.

### **Installing a Battery in the TX433 Transmitter**

1. Access the battery compartment by removing the battery compartment door from the back of the TX433. The door slides down and off the remote.
2. Insert the 9V battery in the back of the remote.
3. Slide the battery compartment door back onto the remote.

4. Push and hold the power button on the TX433 for approximately 1-2 seconds to power it on. The LCD will activate and display the primary screen.

## 2-3 Playing Sounds

The primary function of your Patriot game call is to produce sounds to attract wildlife. This section explains how to turn on the Patriot and the TX433 and how to start playing sounds. The patriot transmitter is not intended to operate the caller at distances shorter than 1 meter (3 feet). If the transmitter is located too close to the caller, the proper operation cannot be ensured.

1. Turn on the Patriot by moving the power switch to the on position (to the right). When powered on, the Patriot pilot light illuminates green, indicating that it is powered on. If the light does not activate, replace your batteries and try again.
2. Turn on the Patriot horn speaker by moving the speaker switch to the right.
3. Turn on the TX433 transmitter by pushing and holding the power button for approximately 1-2 seconds.
4. Notice the black horizontal highlight bar on the TX433 display. The bar moves up and down the screen as you use the “Scroll Up” or “Scroll Down” arrow buttons.
5. Move the highlight bar to one of the sound categories and push the “Select” button. Doing this results in displaying all of the sounds in that particular category. To exit the current category, push the “Back/Menu” button.
6. After moving the highlight bar to the sound you wish to play, push the “Select” button a single time to begin playback. Your selected sound will begin playing at low volume.
7. **To adjust the volume:** Use the “Volume Up” button to raise the volume level to your desired setting. Use the “Volume Down” button to decrease the volume level. The transmitter has 20 volume steps.
8. **To silence the sound:** Push the “Mute” button a single time. When muted, the mute status indicator on the TX433 display shows an “M” and the current sound is silenced. Un-muting is



accomplished by pushing the “Mute” button a second time (the “M” will no longer be displayed and the sound will resume playing).

9. **To switch sounds:** Use the scroll buttons to navigate to a different sound and push the “Select” button. You can switch sounds while the Patriot is actively playing a sound or while muted.
10. **To turn off the TX433:** Push and hold the power button for approximately 1-2 seconds. Be aware that turning off the remote control does not end sound playback on the Patriot. If you are finished calling, use the “Mute” button to silence the Patriot prior to turning off the TX433.
11. **To turn off the Patriot:** Slide the power switch to the off position (to the left). The pilot LED will extinguish.

## 2-4 Favorites

The TX433 allows you to establish a list consisting of 10 of your most frequently used sounds under the “Favorites” menu. These “Favorites” allow for quick selection of your favorite sounds at your predetermined volume level. This section describes the process involved in creating, changing, and using your presets.

### Creating New Favorites

1. Select the “Favorites” menu item on the TX433. If this is your first time working with favorites, favorite 1 is automatically set to Coyote Pup Distress 3 at volume 10.
2. To set a preset, position the black highlight bar on one of the blank preset slots and push the “Select” button a single time.
3. The first step is selecting the sound you wish to use. Use “Sound Up” or “Sound Down” buttons to navigate through your sound list and locate the desired sound. Once found, push the “Select” button to set the sound.
4. Next, select the volume level that you wish to use for this favorite. This is done by using the “Volume Up” or “Volume Down” arrow button. After you have found your desired volume

level, push the “Select” button to set the volume level. This will complete setting up your Favorite.

5. You will notice that the slot you assigned this favorite to now displays the sound name and the volume level for reference.

### **Changing/Overwriting Existing Favorite**

1. Select the “Favorites” menu item on the TX433.
2. Position the highlight bar on the favorite that you wish to change.
3. Push and hold the “Select” button for about 3-4 seconds. Repeat the steps for Creating a New Favorite.

### **Using a Favorite**

1. Select the “Favorites” menu item on the TX433.
2. Position the highlight bar on the preset that you wish to activate.
3. Push the “Select” button a single time to begin playback. The Patriot will begin playing the selected sound at the preset volume level.

## **3. Auxiliary Jack Function**

The AUX jack is provided primarily for the remote control of FOXPRO decoys, and may be suitable for controlling other similar devices. It is NOT intended for the direct control of motors, flashlights, or other devices requiring the internal AUX jack circuitry to switch more than 50 milliamps. The jack tip polarity is positive. Do not exceed 15 volts. You are urged to seek help from a knowledgeable professional before connecting any unapproved device to the jack. Keep in mind that any damage to the FOXPRO caller as a result of improper use of the AUX jack is not covered by the warranty, nor will FOXPRO be liable for damage to any connected devices.

## 4. Using External Speakers

The Patriot is equipped with an external speaker jack which allows you to connect an additional speaker. By connecting a larger and more efficient external speaker to the Patriot, the volume level can be increased significantly. You can find a complete selection of external speakers on the FOXPRO website. The external speaker jack on your Patriot accepts a standard 3.5mm plug. When selecting an external speaker, be sure to use one with an impedance rating of 8-ohms. **Be sure the Patriot is turned OFF before connecting an external speaker!** To connect an external speaker, plug the connector of the external speaker into the external speaker jack on the side of the Patriot. If you wish to have ONLY the external speaker produce sound, you must disable the internal speaker by moving the speaker switch to the left, or off position.

## 5. TX433 Transmitter Detailed Information

This section covers the TX433 in detail including breakdowns and explanations of each menu item.

### 5-1 Primary Display Area



When powered on, the TX433 briefly displays a startup screen (firmware version) and then goes straight to the primary display area (see image to the right). The “Favorites” menu item holds your 10 favorite sounds. Below “Favorites” are your various sound categories. The bottom line of the display is a status bar that shows (in order):

current volume level, mute status, battery level, and elapsed timer. You navigate through the screen with the “Scroll Up” and “Scroll Down” buttons. As you scroll, the black highlight bar moves up and down, respectively. To select a menu item, push the “Select” button. To move back to the previous screen after making a selection, use the “Back/Menu” button.

## 5-2 Main Menu

The main menu provides access to a variety of transmitter configurations. To access the main menu, push the “Back/Menu” button a single time. The available menu options are as follows: “Sound Settings,” “Display/Power,” “Timer/User,” and “Remote Settings.” The following sections cover each of these menu items and their sub-menu items in detail.

## 5-3 Sound Settings: Volume Step

The TX433 has a range of volume steps from 0 – 20. Increasing the volume in the field by increments of 1 may be too slow for some, therefore, this stepping value is configurable. You can choose from 1, 2, and 3.

## 5-4 Sound Settings: Play Mode

This menu allows you to specify which mode of sound playback the Patriot operates on. The available options are: repeat, single play, and jukebox. The default setting is repeat. In **Repeat mode**, the Patriot will play the selected sound repeatedly until you interrupt it. In **Single play mode** the sound will play a single time, then stop. In **Jukebox mode** the sounds play a single time, incrementally. The Play Mode setting is NOT stored between power cycles. You will need to change this setting each time you power on the Patriot remote.

## 5-5 Sound Settings: Fav Mute OR

During normal operation, if the Patriot is muted and you request to play a favorite, the sound is queued for playback, but it cannot be heard until the caller is un-muted. Favorite mute override will take care of this and eliminate the need for un-muting the sound upon preset activation. It works by initially checking to see if mute is active and, if it is, un-mute

the Patriot prior to initiating playback of the sound. Turning on favorite mute override can be done by accessing Sound Settings, highlighting the “Fav Mute OR” menu item, pushing “Select”, then using the “Sound Up” or “Sound Down” to toggle between off and on. Push “Select” a final time to set it. This setting is remembered between power cycles.

## **5-6 Display/Power: Backlight**

This setting allows you to change the intensity of the backlight in a range from 5% - 100%. The lower the intensity, the better your battery life will be.

## **5-7 Display/Power: Bklt T.O.**

This setting allows you to set the duration for the backlight timeout. The backlight illuminates every time a button is pressed. If the backlight is illuminated and you do not push a button within the set period of time, the backlight will automatically shut off. Available values are 15 seconds, 30 seconds, and 1 minute.

## **5-8 Display/Power: Contrast**

This setting allows you to adjust the screen contrast. In ‘normal’ display mode (see 5-9 Display/Power: LCD Mode), the higher the value, the darker the text will appear. In ‘inverse’ display mode, the higher the value, the darker the background will appear.

## **5-9 Display/Power: LCD Mode**

This setting allows you to set the desired display mode. Available options include normal and inverse. In normal mode, the text will appear as black and the background will be light. In inverse mode, the background will be black with light text.

## **5-10 Display/Power: Auto Off**

If you do not push a button on the remote for a set amount of time, the remote will automatically power down to conserve battery life. The available options for this setting include 30 minutes, 45 minutes, 1 hour, 2 hours, and 4 hours.

## **5-11 Timer/User: Stand Tmr**

The elapsed timer (located on the bottom right of the display) allows you to see how long you have been on a stand. The timer starts as soon as you turn on the Patriot transmitter. You can reset the timer by accessing the Main Menu, selecting Timer/User option, and then selecting the “Stand Timer Reset.” The timer will automatically reset to 00:00 if it is allowed to continue beyond 99:59.

## **5-12 Timer/User: Alarm**

The Patriot remote features a visual alarm that can be set to go off after a span of time. The available times are represented in minutes: 1 – 15 (individual steps) and 20-60 (steps of 5). When the alarm is set and the configured time span passes, the stand timer (or clock if set to display the clock) will display a confirmation message and the timer indicator will begin to flash. To set an alarm, select the “Alarm (minutes)” menu item, push the “Select” button, and then use the “Scroll Up” or “Scroll Down” buttons to find the desired time value. When the desired time value is selected, push the “Select” button to set the alarm.

## **5-13 Timer/User: USER 1 & USER 2**

User button 1 and 2 can be assigned a function of your choice for quick one-button access. You can choose from: Favorite 1, Favorite 2, Favorite 3, AUX, Recall, Timer reset, and Backlight.

## **5-14 Remote Settings: Download List**

Any time you reprogram the Patriot to add new sounds or rearrange existing sounds, you must download a new copy of the play list to the transmitter. This menu item will guide you through that process. In order to download the playlist, you will need a 3.5mm stereo male-to-male cable (included). See section 6-3 for more information.

## **5-15 Remote Settings: AUX Cntrl**

The auxiliary jack operation specifications can be changed from either momentary or latched. All FOXPRO decoys require that the jack be setup for momentary.

## 5-16 Remote Settings: View

The TX433 can display your sounds either by general numerical listing or by category listing. Sound categories are the easiest to navigate if you have a large number of sounds. The TX433 supports up to 25 unique categories.

## 5-17 Remote Settings: Snd Num

The TX433 displays your sound list in a numerical format based upon the index value of each sound file. The sounds are numbered from 000 – 299. You can choose to either have the index values visible in your sound list or you can hide them. The advantage of hiding the numbers is that the sound names might be easier to read. The options for this setting are “Show” and “Hide.”

## 5-18 Remote Settings: About Info

The About Info screen displays a variety of information pertaining to version number, number of sounds loaded, number of favorites, and transmitter health.

## 5-19 Remote Settings: Cable Detect

If cable detect is turned on, the transmitter will automatically prompt you to perform the download list function when a 3.5mm stereo cable is connected to the sound upload jack. You can manually initiate the download list process, if you prefer, by disabling this feature.

# 6. Programming the Patriot

The Patriot can store up to 300 sounds in total. From the factory, it's loaded with 35 premium sounds along with all current free sounds. **All free sounds are prefixed with “F\_” for easy recognition.** FOXPRO offers free software for both PC and Mac that assists you in this process. The FOXPRO website contains an extensive library of free sounds and sounds that can be purchased and installed in the TurkeyPro. The website also contains extensive information on how to use the programming software. We strongly recommend that you view the online resources to become familiar with the programming process including watching the walkthrough video.

## 7. Maximizing Remote Range

Remote range can be affected by many factors. Some of these factors can be controlled while others cannot. In order to achieve the best possible remote range with your Patriot digital game call system, it is recommended that the following points be observed:

- Fully extend the telescopic antenna on the TX433 remote control.
- Always use a high-quality alkaline or lithium battery in the remote.
- Always maintain clear line of sight between the remote control and the Patriot. Any obstructions—no matter how significant or insignificant—can adversely affect the radio signal.
- Keep the remote control a minimum of six inches away from your body, gun barrel, and metal shooting sticks as these things can detune the remote control.
- Hold the remote control vertically with the antenna pointing skyward (see image below):

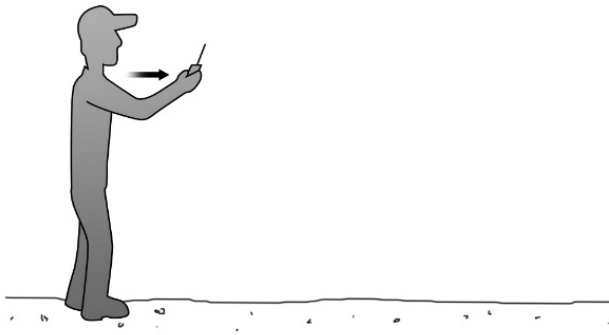

- Avoid using the device remotely when you are near power lines, cellular phone towers, and radar (such as near airports or military installations).
- Try to elevate the caller off of the ground by approximately three feet. This can greatly maximize your overall remote control range.



## 8. Product Care & Maintenance

**Avoid exposure to all precipitation and moisture.** Moisture (perhaps from rain, snow, condensation, or other) can potentially enter the unit or the battery compartment and cause serious problems. Proper care should be taken to mitigate the introduction of moisture into the machine and make sure that no moisture is present during storage. Moisture can quickly lead to corrosion, electrical shorts, and even rust—all of which can render the unit damaged and out of warranty. This type of damage is preventable! If you are operating in rainy, wet conditions, it is recommended that you place the unit inside of a large plastic storage bag or use a water/weatherproof deployment bag to keep water from getting to it. When storing the unit for prolonged periods, be sure that you keep it in a dry location. **Remove batteries prior to storage or extended periods of inactivity!** All batteries, whether alkaline or rechargeable, should be removed from the game calls, decoys, and transmitters prior to storage or periods of inactivity. Batteries left inside of electronic devices can leak over time. Damages caused by this can be severe and potentially destroy the electrical components. To prevent this from happening, simply remove all batteries from all devices before you put them away. Keep in mind: damage caused by battery leakage is not covered under warranty.

## 9. Troubleshooting

**Problem:** Patriot will Not Turn On. **Solution:** Make sure you have fresh batteries installed. If using rechargeable batteries, make sure they are fully charged. Inspect the battery tray for signs of corrosion.

**Problem:** Patriot does not produce any sound. **Solution:** Check that the speaker is in the “on” position (to the right).

**Problem:** Cannot transfer sound list to Patriot transmitter. **Solution:** This typically stems from an error in the play list in the Patriot. If you recently added new sounds, double-check the programming for errors such as duplicate or missing sound numbers.

**Problem:** Patriot transmitter does not turn on. **Solution:** Install fresh batteries and try again.

**Problem:** Poor battery life in extreme cold weather conditions.

**Solution:** Cold weather operations can take a serious toll on alkaline batteries. It is strongly recommended that you use lithium or rechargeable NiMH batteries to get the best performance in cold weather.

**Problem:** Patriot is not being recognized by computer . **Solution:** Make sure that the Patriot is turned OFF while connected to the computer. Make sure that the memory card is properly situated in the socket.

**Problem:** Pilot light / LED is blinking. **Solution:** This is the low battery indicator. Replace your batteries.

**Problem:** Pilot light blinks 5 times and then turns off. **Solution:** Problem detected with the memory card. Contact support.

## 10. FCC & IC Information

### RF Exposure Safety Notice

The Patriot transmitter is not intended to be operated closer than 20cm (about 8 inches) to your body. The transmitter can produce a radiated RF field similar to that of a standard cell telephone, although the duty cycle of this RF field is much lower than that of a cell telephone. Using the transmitter closer than 8 inches to your body can increase your exposure to RF energy levels thought by some to be harmful. Additionally, operation in close proximity to your body can detune the antenna causing a decrease in operating performance.

The antenna(s) used for this transmitter must be installed to provide a separation distance of at least 20 cm from all persons and must not be co-located or operating in conjunction with any other antenna or transmitter. End-users and installers must be provided with antenna installation instructions and transmitter operating conditions for satisfying RF exposure compliance.

### FCC Information

NOTE: This equipment has been tested and found to comply with the limits for a Class B digital device, pursuant to Part 15 of the FCC Rules. These limits are designed to provide reasonable protection against harmful interference in a residential installation. This equipment generates, uses, and can radiate radio frequency energy and, if not installed and used in accordance with the instructions, may cause harmful interference to radio communications. However, there is no guarantee that the interference will not occur in a particular installation. If this equipment does cause harmful interference to radio or television reception, which can be determined by turning the equipment off and on, the user is encouraged to correct the interference by one or more of the following measures:

- Reorient or relocate the receiving antenna.
- Increase the separation between the equipment and receiver.
- Connect the equipment into an outlet or circuit different that to which the receiver is connected.
- Consult the dealer or an experienced radio/TV technician for help.

Operation is subject to the following two conditions: (1) this device may not cause harmful interference, and (2) this device must accept any interference received, including interference that may cause undesired operation of this device. Modifications not expressly approved by the manufacturer could void the user's authority to operate the equipment under FCC rules.

### **Industry Canada Notice**

This device complies with Industry Canada licence-exempt RSS standard(s). Operation is subject to the following two conditions: (1) this device may not cause interference, and (2) this device must accept any interference, including interference that may cause undesirable operation of the device.

Le présent appareil est conforme aux CNR d'Industrie Canada applicable aux appareils radio exempts de licence. L'exploitation est autorisée aux deux conditions suivantes : (1) l'appareil ne doit pas produire de

brouillage, et (2) l'utilisateur de l'appareil doit accepter tout brouillage radioélectrique subi, même si le brouillage est susceptible d'en compromettre le fonctionnement.

**Note:** Units exported beyond the boundaries of North America are not FCC certified. FOXPRO Inc. makes every attempt at complying with regional regulations governing radio spectrum. However, it is the user's responsibility to ensure compliance with local laws and ordinances that govern the use of radio controlled devices in the area of operation.

## 11. Warranty Statement

Your FOXPRO® game call is warranted to be free from defects in materials and workmanship that diminish its usefulness for a period as established for 3 years from the date of purchase if the item was purchased from a FOXPRO Authorized Retailer. Return the unit prepaid and packaged securely along with proof of purchase to FOXPRO. Include a note describing the defect or problem. This limited warranty is void if the unit is physically damaged, used in a manner contrary to intended use, or otherwise abused, either intentionally or unintentionally. Also specifically excluded are batteries and damage caused by attempts to charge batteries not intended to be recharged, and water damage. Examples of non-warranty issues: product ceases to work after exposure to water (in the form of any precipitation), moisture, or other elemental forces; product is physically damaged from dropping, running over with any vehicle, falling from any surface and impacting with the ground, gunshot, misuse, neglect, abuse, animal attack; product ceases to work as a result of battery leakage, battery damage, intentional or unintentional wiring accidents, connecting an unapproved charging device to the product, overpowering, and incorrect installation of batteries; product ceases to work after connecting an unapproved external auxiliary device.